



第46回日本神経科学大会

The 46th Annual Meeting of the Japan Neuroscience Society

銀河に輝く 神経科学

— Towards the Galaxy of Neuroscience —

8/1 Tue. - 4 Fri. 2023

会場
Venue

仙台国際センター
SENDAI INTERNATIONAL CENTER

大会長
President

小林 和人 (福島県立医科大学)
Kazuto Kobayashi (Fukushima Medical University)

Important Dates

Call for Symposia August 31 Wed. 2022

Call for Papers February 10 Fri. 2023

Plenary Lectures



Susan L. Ackerman
University of California,
San Diego / HHMI



Ray Dolan
University College London
/ Max Planck UCL Centre



Anne-Laura van Harmelen
Leiden University
/ University of Cambridge



Larry Young
Emory University

Sponsorship Prospectus

第46回日本神経科学大会事務局

〒532-0003 大阪府大阪市淀川区宮原2-14-14

新大阪グランドビル6F 株式会社エー・イー企画内

TEL: 06-6350-7163 FAX: 06-6350-7164 E-mail: jns2023@aeplan.co.jp

Neuroscience 2023 Secretariat

6F Shin-Osaka Grand Bldg., 2-14-14, Miyahara, Yodogawa-ku, Osaka,

521-0003, JAPAN (c/o A & E Planning, Co., Ltd.)

E-mail: jns2023@aeplan.co.jp

Ver.20220616



The 46th Annual Meeting of the Japan Neuroscience Society

General Information



General Information

Name

The 46th Annual Meeting of the Japan Neuroscience Society

President

Kazuto Kobayashi (Fukushima Medical University)

Theme

Towards the Galaxy of Neuroscience

Date

August 1-4, 2023

Venue

Sendai International Center
Aobayama, Aoba-ku, Sendai 980-0856, Japan
<http://www.aobayama.jp/english/>

Expected number of participants

3,000 (Incl. invitees)

Secretariat of the Japan Neuroscience Society

The Japan Neuroscience Society
Hongo Bldg., 9F, 7-2-2 Hongo, Bunkyo-ku, Tokyo 113-0033, Japan
Tel. +81-3-3813-0295

Contact

Neuroscience 2023 Sponsorship Secretariat (c/o A & E Planning, Co., Ltd.)
Shin-Osaka Grand Bldg., 6F, 2-14-14, Miyahara, Yodogawa-ku, Osaka, 532-0003, Japan
E-mail : e-jns2023@aeplan.co.jp



Organizers (1)

President

Kazuto Kobayashi Fukushima Medical University

Executive Committee

Chair Noriko Osumi Tohoku University

Vice chair Ken-Ichiro Tsutsui Tohoku University

Members Kentaro Abe Tohoku University

Satoshi Eifuku Fukushima Medical University

Shin Fukudo Tohoku University

Kaoru Goto Yamagata University

Yoshio Iguchi Fukushima Medical University

Yuko Maejima Fukushima Medical University

Motoko Maekawa Tohoku University

Ko Matsui Tohoku University

Yoshiya Matsuzaka Tohoku Medical and Pharmaceutical University

Hajime Mushiake Tohoku University

Katsumi Nakajima Iwate Medical University

Yuji Owada Tohoku University

Kazuhiro Sakamoto Tohoku Medical and Pharmaceutical University

Takuya Sasaki Tohoku University

Kenju Shimomura Fukushima Medical University

Hideaki Takeuchi Tohoku University

Hiromu Tanimoto Tohoku University

Hiroaki Tomita Tohoku University

Shinya Ueno Hirosaki University

Satoshi Waguri Fukushima Medical University

Hiroyuki Yaginuma Fukushima Medical University



Organizers (2)

Program Committee

Chair	Yoshikazu Isomura	Tokyo Medical and Dental University
Vice chair	Tomomi Shimogori	RIKEN
Core members	Tomoyuki Furuyashiki	Kobe University
	Takashi Hanakawa	Kyoto University
	Kenichi Ohki	The University of Tokyo
	Makoto Osanai	Osaka University
	Hideaki Shimazaki	Hokkaido University
	Hidehiko Takahashi	Tokyo Medical and Dental University
	Hiroaki Wake	Nagoya University
	Dan Ohtan Wang	Kyoto University
	Ayako M. Watabe	The Jikei University School of Medicine
	Koji Yamanaka	Nagoya University
	Yumiko Yoshimura	National Institute For Physiological Sciences

Organizing Committee

Masashi Aoki	Tohoku University
Masazumi Fujii	Fukushima Medical University
Kohji Fukunaga	Tohoku University
Teruhiko Higuchi	National Center of Neurology and Psychiatry
Toshio Iijima	Tohoku University
Hiroshi Ito	Fukushima Medical University
Kazuaki Kanai	Fukushima Medical University
Hidehiro Mizusawa	National Center of Neurology and Psychiatry
Shin-Ichi Niwa	Fukushima Medical University
Kyoko Suzuki	Tohoku University
Yoshikazu Ugawa	Fukushima Medical University
Hirooki Yabe	Fukushima Medical University



Budget (as of October,2021)

Income			
Item		Amount (JPY)	Remarks
1.	Registration fees	33,495,000	2,200 participants
2.	Seminar sponsorship	19,820,000	8 sponsors
3.	Sponsorship package	5,420,000	4 sponsors
4.	Exhibition	14,195,000	68 booths
5.	Advertising	3,916,000	Program booklet ad, Web banner etc.
6.	Donation	23,010,000	Incl. grants from various foundations, etc.
7.	Loan from the society	2,000,000	
Total		101,856,000	

Expenditure			
Item		Amount (JPY)	Remarks
1.	Preparation	<u>27,612,630</u>	
	1) Personnel	12,323,000	
	2) System-related	8,233,600	Incl. website, abstract submission/registration systems
	3) Print/Production	4,438,150	Incl. translation
	4) Communication/Transportation	2,617,880	
2.	On-site operation	<u>72,070,722</u>	
	1) Venue	16,000,000	
	2) Equipment	28,373,510	
	3) Personnel	10,476,012	
	4) Invitation	8,000,000	
	5) Meeting	5,531,300	
	6) Miscellaneous	1,589,900	
	7) Open lecture	2,100,000	
3.	Post-meeting	<u>3,026,000</u>	
4.	Reserve fund	<u>853,352</u>	
Total		101,856,000	



Cancellation Policy

Please agree to the following policy when applying.

Cancellation of application

Once an application is received, the application cannot be cancelled unless the organizing committee recognizes it is due to a reason beyond one's control. Should the organizing committee accept a cancellation, please send us the reason of the cancellation in a written notice and pay a cancellation fee based on the day your notice is received by the secretariat.

[Cancellation fee]

When a cancellation notice is received ...

by the application deadline : 50% of the amount billed

on and after the application deadline : Full amount billed

Change or Cancellation of the annual meeting

The annual meeting and the exhibition may be changed or cancelled due to natural disasters and other reasons that are beyond one's control, or for reasons that are not in the scope of the organizer's responsibility.

The organizer will not pay compensation to sponsor companies for damages or losses caused by such changes. In case the annual meeting or the exhibition is cancelled due to a reason mentioned above, the organizer will deduct preparation costs from the sponsorship fee and refund the difference to sponsor companies depending on the timing of the decision to cancel.



The 46th Annual Meeting of the Japan Neuroscience Society

Sponsorship Package



Sponsorship Package (1)

Platinum / Gold / Silver sponsorship packages are available.

Application deadline for sponsorship package: March 15, 2023

* Please decide on the theme, chair, and speaker for luncheon seminar before applying. If these are not decided, the application will not be accepted.

Platinum

JPY2,970,000 (Incl.tax)

● The package includes

Normal price (JPY, Incl.tax)

1	Luncheon seminar	×1	First priority to choose the date & room	1,430,000~1,650,000
2	Exhibition booth (A)	×5	First priority to choose the booth location	1,375,000
3	Web banner	×1		220,000
4	Meeting pass	×5	Incl. admission to the banquet	192,500
5	Slide projection during intermissions	×1	All lecture rooms and exhibition/posters site	110,000

Total normal price 3,327,500~3,547,500

Gold

JPY2,310,000 (Incl.tax)

● The package includes

Normal price (JPY, Incl.tax)

1	Luncheon seminar	×1	Second priority to choose the date & room	1,430,000~1,650,000
2	Exhibition booth (A)	×2	Second priority to choose the booth location	550,000
3	Web banner	×1		220,000
4	Meeting pass	×3	Incl. admission to the banquet	115,500
5	Slide projection during intermissions	×1	All lecture rooms and exhibition/posters site	110,000

Total normal price 2,425,500~2,645,500

Silver

JPY1,980,000 (Incl.tax)

● The package includes

Normal price (JPY, Incl.tax)

1	Luncheon seminar	×1	Possible to choose the date & room	1,430,000
2	Exhibition booth (A)	×1	Possible to choose the booth location	275,000
3	Web banner	×1		220,000
4	Meeting pass	×2	Incl. admission to the banquet	77,000
5	Slide projection during intermissions	×1	All lecture rooms and exhibition/posters site	110,000

Total normal price 2,112,000



Sponsorship Package (2)

Please refer to the respective pages for details of each sponsorship menu.

○ Meeting website: <https://neuroscience2023.jnss.org/en/index.html>

○ Application: Please apply via an online application form on the sponsorship page of the meeting website.
* The application cannot be cancelled unless the organizing committee recognizes it is due to a reason beyond one's control. Please check the cancellation policy for details.

○ Contact: Neuroscience 2023 Sponsorship Secretariat (c/o A & E Planning, Co., Ltd.)
E-mail : e-jns2023@aeplan.co.jp

* Priority in each package level will be given on a first-come-first-served basis.

* If you wish to hold a luncheon seminar as a web seminar, please contact the sponsorship secretariat.



The 46th Annual Meeting of the Japan Neuroscience Society

Luncheon Seminar



Luncheon Seminar (1)

Luncheon seminars will be co-hosted with The 46th Annual Meeting of the Japan Neuroscience Society.

Venue: Lecture room or Online (Web seminar using Zoom)

Date & Time: August 1-3, 2023 at lunch time

Length: 50 minutes

Language: Japanese or English

Fee:

Date	Time *Tentative	Capacity *Tentative	Fee (Incl.tax)
August 1	11:55 - 12:45	300 - 480 seats	JPY1,650,000
		180 - 240 seats	JPY1,430,000
August 2	11:55 - 12:45	300 - 480 seats	JPY1,650,000
		180 - 240 seats	JPY1,430,000
August 3	11:55 - 12:45	300 - 480 seats	JPY1,650,000
		180 - 240 seats	JPY1,430,000

● **Option: On-site + Live streaming**

Live streaming is available for above fee + JPY550,000 (Incl.tax), if you wish live streaming besides on-site.

3-6 seminars per day will be held in parallel. It is subject to change depending on the number of applications.

Please note that the date & room of each seminar will be decided by the organizing committee with reference to the preferences of co-hosts.

* The time slot may be changed for scheduling reasons.

* If you wish to hold a luncheon seminar as a web seminar only, please contact the sponsorship secretariat. (Only web seminar: JPY1,430,000 (Incl. tax))



Luncheon Seminar (2)

- Application: Please apply via an online application form on the sponsorship page of the meeting website.
* The application cannot be cancelled unless the organizing committee recognizes it is due to a reason beyond one's control. Please check the cancellation policy for details.
- Application deadline: Advance reservation available March 15, 2023
* Please decide on the theme, chair, and speaker for luncheon seminar before applying. If these are not decided, the application will not be accepted.
- Payment: An invoice will be sent after application. Please make a payment before the due date written on the invoice.
*Bank transfer fees shall be borne by the applicant.
- Disclosure of information: We agree that the sponsors disclose their contributions.
- Contact: Neuroscience 2023 Sponsorship Secretariat (c/o A & E Planning, Co., Ltd.)
E-mail : e-jns2023@aeplan.co.jp
- Remarks
 - Lecture room facilities
Fees for standard audio-visual equipment (projector, screen, microphone, etc.) and staff in charge of video, audio, and lighting are included in the seminar fee.
Also, 2 meeting passes to participate in the meeting program are to be provided.
If any other equipment such as video and audio recording is required, charges will be incurred separately. Please contact the secretariat.
 - Program
Program will be organized by the executive committee and informed to the seminar co-hosts from the secretariat.
 - What is NOT included in the seminar fee
The following fees are NOT included in the seminar fee.
Actual cost will be charged by the secretariat after the meeting.
 - Box lunch with packet drink (green tea) for participants * Not required for web seminar
Please make an arrangement for lunch as a seminar will be held during lunchtime.
Box lunch with packet drink (green tea): JPY1,500 /box *tentative
The necessary number of box lunches will be decided by the co-host after the application deadline.
The secretariat will then place an order for the total number of all.



Luncheon Seminar (3)

- Options

- ① Operating staff (announcement, timekeeping, distributing handouts and lunch, guide, etc.)

- *This will be arranged separately from the operating staff for the meeting.

- ② Honorarium and travel expenses for speaker and chair

- ③ Signage/Display: Signboards in front of the room etc.

- ④ Additional equipment: video and audio recording / simultaneous interpretation / facilities for anteroom, etc.

- ⑤ Anteroom: room charge, food, and drink

- ⑥ Operating expenses

- * If you order any of above options, a 10% service fee will be charged in addition to the total amount of option fees.

- An advance reservation system for luncheon seminar tickets will be available for participants.

- The information of participants who made a reservation will be provided to each seminar co-host.

- The schedule and procedure will be notified from the secretariat after the application.

- Acquisition of Personal Information and Use of the Reservation System

- Please read the following terms and conditions regarding acquisition of personal information and use of the reservation system, and check the box on the reservation form.

- 1. Resale of acquired personal information is prohibited.

- 2. Personal information acquired shall be used only within the company unless otherwise agreed by an individual.

- 3. If an individual refuses to provide information or communicate, the use of his/her personal information shall be stopped.

- 4. Appropriate precautionary measures should be taken by assigning a personal information manager to prevent the loss or leakage of acquired personal information.

- 5. If personal information that is clearly seems to be erroneous is obtained in any way, it will not be used and will be deleted.

- 6. Other appropriate measures shall be taken in accordance with the Act on the Protection of Personal Information.



The 46th Annual Meeting of the Japan Neuroscience Society

Advertising

Pocket program advertising

Web banner advertising on the meeting website

Screen advertising

Congress bag sponsor

Flyer Insert in congress bag

Neck strap sponsor



Advertising (1)

■ Pocket program advertising

- Advertising medium: Pocket Program of The 46th Annual Meeting of the Japan Neuroscience Society
- Book size, Printing method: B5 (257 mm height×182 mm width), approx. 40 pages
Offset printing (Front cover: 4 colors / Body: Black and White), Perfect binding
- Circulation: 2,700
- Subject of distribution: Meeting participants
- Budget: JPY1,100,000
- Rate: *Incl.tax

Page	Size	Color	Rate	No. of slots
Cover 4 (Back cover)	B5 : 1 page	4 colors	JPY275,000	1
Cover 2 (Inside front)	B5 : 1 page	Black and White	JPY165,000	1
Cover 3 (Inside back)	B5 : 1 page	Black and White	JPY132,000	1
Back matter 1 page	B5 : 1 page	Black and White	JPY88,000	Up to 10

Please note that ads for back matter will be assigned by the organizer.

- Application: Please apply via an online application form on the sponsorship page of the meeting website.
- Application deadline: April 28, 2023
- Ad submission deadline: May 10, 2023
- Ad size: 225 mm height×150 mm width
- Ad requirements: Print-ready data (Please attach a print sample.)
- Format
 1. Adobe illustrator
Please outline all fonts, and embed all images. Also, please specify your OS and the version of Illustrator used for creating the ad.
Proofreading will be performed by the printer. Please note that a proof sheet will not be sent to you.
 2. PDF
Please outline all fonts, and embed all images. If MS-Word or MS-PowerPoint is used for creating the ad, please make sure to specify the application used.
Please note that submitted data may not be accepted.
- Ad submission: Please send an ad data to the sponsorship secretariat by e-mail.
- Payment: An invoice will be sent after publishing. Please make a payment by the due date written on the invoice.
- Disclosure of information: We agree that the sponsors disclose their contributions.



Advertising (2)

■ Web banner advertising on the meeting website

- Advertising medium: Website of The 46th Annual Meeting of the Japan Neuroscience Society
- Advertising form: Web banner advertising
- URL: <https://neuroscience2023.jnss.org/en/index.html>
Open in July, 2022
- Number of banners: 10 *tentative
- Display method: Top of all pages of the website
Placement on Program search page or Program page are also available.
Please ask the sponsorship secretariat for details.
Random display - banners appear at random when the website is visited.
- Rate: JPY220,000 /banner (Incl.tax)
- Application: Please apply via an online application form on the sponsorship page of the meeting website.
- Placement period: Applications are accepted any time after the website is launched in July, 2022.
Placement is guaranteed until 1 month after the meeting.
- Banner size: Height 80 pixels × Width 228 pixels
- Format: GIF (Animation GIF, Infinite loop are acceptable) /JPEG/PNG etc.
- Banner submission: Please send a banner data to the sponsorship secretariat by e-mail.
Also, please send the URL to be linked to the banner as well.
- Payment: A banner will be placed within 7 business days after receipt, and then, an invoice will be sent. Please make a payment by the due date written on the invoice.
- Disclosure of information: We agree that the sponsors disclose their contributions.
- Contact: Neuroscience 2023 Sponsorship Secretariat (c/o A & E Planning, Co., Ltd.)
E-mail : e-jns2023@aeplan.co.jp



Advertising (3)

■ Screen advertising

- Advertising medium: Screen of The 46th Annual Meeting of the Japan Neuroscience Society
- Advertising form: Screen advertising
- Details: Promotional slides and videos will be projected on the screens in lecture rooms and rest area during break times.
- Number of spots: 10 *tentative
- Display method: Loop, 20 seconds per 1 spot
- Rate: JPY165,000 /spot (Incl.tax)
- Application deadline: June 15, 2023
- Application: Please apply via an online application form on the sponsorship page of the meeting website.
- Format: Microsoft PowerPoint (Resolution: XGA / Aspect ratio: 4:3)
- Ad submission: Please send an ad data to the sponsorship secretariat by e-mail.
- Payment: An invoice will be sent before the meeting. Please make a payment by the due date written on the invoice.
- Disclosure of information: We agree that the sponsors disclose their contributions.
- Contact: Neuroscience 2023 Sponsorship Secretariat (c/o A & E Planning, Co., Ltd.)
E-mail : e-jns2023@aeplan.co.jp



Advertising (4)

■ Congress bag sponsor

- Advertising medium: Congress bag of The 46th Annual Meeting of the Japan Neuroscience Society
- Advertising form: Ad printed on congress bag
- Details: Your company's logo will be printed on the congress bags which will be distributed to participants.
- Number of spots: 2
- Rate: JPY330,000 /spot (Incl.tax)
- Application deadline: May 15, 2023
- Application: Please apply via an online application form on the sponsorship page of the meeting website.
- Format: Adobe illustrator, Print-ready data
- Ad submission: Please send an ad data to the sponsorship secretariat by e-mail.
- Payment: An invoice will be sent before the meeting. Please make a payment by the due date written on the invoice.
- Disclosure of information: We agree that the sponsors disclose their contributions.
- Contact: Neuroscience 2023 Sponsorship Secretariat (c/o A & E Planning, Co., Ltd.)
E-mail : e-jns2023@aeplan.co.jp



Advertising (5)

■ Flyer Insert in congress bag

- Advertising medium: Flyer Insert in congress bag of The 46th Annual Meeting of the Japan Neuroscience Society
- Advertising form: Flyer
- Details: Flyers will be inserted in the congress bags which will be distributed to participants.
- Number of flyers: 5 *Only 1 flyer per company
- Rate: JPY110,000円 /flyer (Incl.tax)
- Application deadline: June 15, 2023
- Application: Please apply via an online application form on the sponsorship page of the meeting website.
- Size of flyer: A4, 1 page
No rules for printing and colors (Both are acceptable: double/single sided printing, 4 colors/black and white)
- Flyer submission: Please send 3,000 copies of the flyer to the designated address given by the sponsorship secretariat at a later date.
- Payment: An invoice will be sent before the meeting. Please make a payment by the due date written on the invoice.
- Disclosure of information: We agree that the sponsors disclose their contributions.
- Contact: Neuroscience 2023 Sponsorship Secretariat (c/o A & E Planning, Co., Ltd.)
E-mail : e-jns2023@aeplan.co.jp



Advertising (6)

■ Neck strap sponsor

- Advertising medium: Neck strap of The 46th Annual Meeting of the Japan Neuroscience Society
- Advertising form: Ad on neck strap
- Details: Your company's logo will be printed on the neck straps which will be worn by participants.
- Number of slot: 1
- Rate: JPY1,650,000円 (Incl.tax)
- Application deadline: May 15, 2023
- Application: Please apply via an online application form on the sponsorship page of the meeting website.
- Format: Adobe illustrator, Print-ready data
- Ad submission: Please send an ad data to the sponsorship secretariat by e-mail.
- Payment: An invoice will be sent before the meeting. Please make a payment by the due date written on the invoice.
- Disclosure of information: We agree that the sponsors disclose their contributions.
- Contact: Neuroscience 2023 Sponsorship Secretariat (c/o A & E Planning, Co., Ltd.)
E-mail : e-jns2023@aeplan.co.jp



The 46th Annual Meeting of the Japan Neuroscience Society

On-demand streaming



On-demand streaming

■ On-demand streaming

- Details: Your seminar can be distributed on-demand in the online conference system "Confit", which is the entrance to timetable, abstract viewing, and online lectures, and can be linked to YouTube, etc.
* A pre-recorded video is available, live streaming is not available.
- Streaming period: July 25 – August 31, 2023 *tentative
- Applicable products & services: Medical and life science research related instruments, reagents, disposables, computer systems including software, database, etc., contract services, introduction/recruitment of universities and research institutions, other research related services, books, and translation service.
Applications from company that does not have products or services mentioned above will not be accepted.
- Fee: JPY550,000 /slot (Incl.tax)
- Application deadline: May 31, 2023
- Application: Please apply via an online application form on the sponsorship page of the meeting website.
- Payment: An invoice will be sent before the meeting. Please make a payment by the due date written on the invoice.
- Disclosure of information: We agree that the sponsors disclose their contributions.
- Contact: Neuroscience 2023 Sponsorship Secretariat (c/o A & E Planning, Co., Ltd.)
E-mail : e-jns2023@aeplan.co.jp



The 46th Annual Meeting of the Japan Neuroscience Society

Exhibition



Exhibition (1)

■ Exhibition

- Schedule: July 31, 2023 14:00 - 17:00 (Installation)
August 1, 2023 9:00 - 17:00
August 2, 2023 9:00 - 17:00
August 3, 2023 9:00 - 17:00 (Dismantling 17:00 -)
*The above schedule is subject to change. Please be sure to check the exhibitor's manual which will be sent at least 1 month prior to the meeting.
- Venue: Exhibition hall and Meeting room 1+2, Sendai International Center
- Applicable products & services:
Medical and life science research related instruments, reagents, disposables, computer systems including software, database, etc., contract services, introduction/recruitment of universities and research institutions, other research related services, books, and translation service.
Applications from company that does not have products or services mentioned above will not be accepted.
- Number of booths: 100
- Application deadline: April 28, 2023
- Application: Please apply via an online application form on the sponsorship page of the meeting website.
(1) A confirmation e-mail will be sent after you have submitted an application.
(2) Then, another e-mail confirming the receipt of your application will be sent from the sponsorship secretariat.
Your application will be complete by receiving (1) and (2) mentioned above.
Please note that applicants that are not eligible for application will be notified later after due consideration. When you have any troubles applying online, please contact the sponsorship secretariat.
- Payment: An invoice will be sent before the meeting. Please make a payment by the due date written on the invoice.
* Please make sure to inform us if the payment will not be made by the due date on the invoice due to unforeseen circumstances. Otherwise, your application will be cancelled and a cancellation charge will be incurred. Please refer to the cancellation policy page for details.
- Disclosure of information: We agree that the sponsors disclose their contributions.
- Contact: Neuroscience 2023 Sponsorship Secretariat (c/o A & E Planning, Co., Ltd.)
E-mail : e-jns2023@aeplan.co.jp



Exhibition (2)

- Booth assignment: After application is closed, booths will be assigned in consideration of the type, shape, and weight of the exhibits and the number of booths applied for, and notify the exhibitors in the exhibitor's manual. Please note that exhibitors' briefing will not be held.

* If you wish to set up a booth side-by-side with your affiliate or associate companies, please inform the sponsorship secretariat by the application deadline.
- Use of display table: Each booth is equipped with a display table. Please enter the number of booths that do not need a display table in the application form.
- Exhibit management: Please note that the exhibitors are responsible for the management of their own exhibits, and the secretariat shall not compensate for any damages caused by thefts, losses, fire or inevitable accidents during the exhibition.
- Others: Distribution of flyers, catalogs, sample products, etc., other than in front of your own booth (inside and outside the buildings where the exhibition and lectures take place) is prohibited. As many exhibitors are expected to participate in the exhibition, your cooperation would be highly appreciated. However, there will be some exceptions such as cases approved by the Executive Committee.
- Use of exhibition fee: Part of exhibition fee will be used for arranging "Stamp rally"(Prizes etc.) which is to be held at the exhibition hall. We welcome your sponsorship for prizes as well. If you are interested in, please contact the secretariat.



Exhibition (3)

○Booth type and Fee

◆Type A: JPY275,000 /booth (Incl.tax)

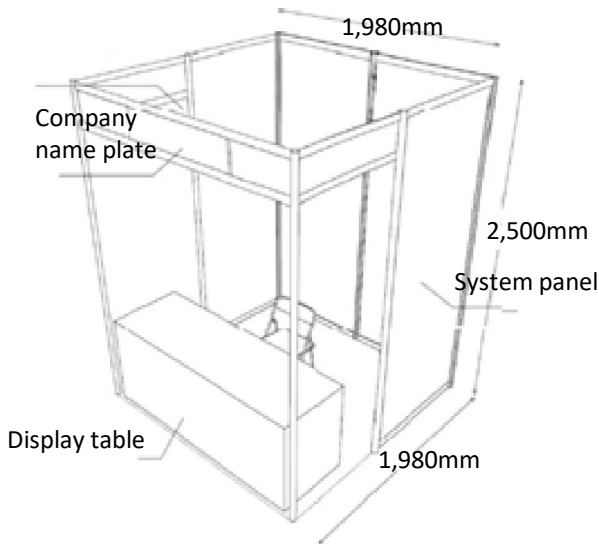

○Applicable products & services:

Medical and life science research related instruments, reagents, disposables, computer systems including software, database, etc., and contract services.

○Booth size: W1,980×D1,980×H2,500 (mm)

○Furniture:

Display table covered with a white cloth (W1,800×D900×H approx.720(mm)), Company name plate, Lighting (FL40W), 1 chair (The no. of chairs depends on the no. of booths applied for.)

○System panels are used for booths.

Pushpins and nails are not available on the panels to attach panel or poster.

○4 name badges per booth will be provided for the exhibition staff.

○1 meeting pass to participate in the meeting program will be provided.

◆Type B: JPY33,000 /booth (Incl.tax)

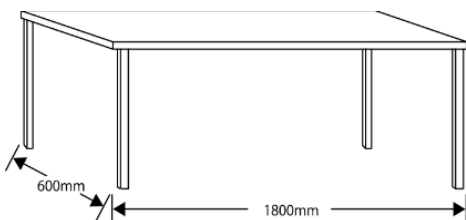

○Applicable products & services:

Related books, translation services, etc.

○ Booth size: W1,800×D600 (mm)

○ Furniture:

Display table covered with a white cloth (W1,800×D600 (mm)), 1 chair, Company name plate

○4 name badges per booth will be provided for the exhibition staff.



Exhibition (4)

◆ Type C: JPY110,000 /booth (Incl.tax)

* The specifications of the booth will be the same as for Type A, but the eligible applicants are different.

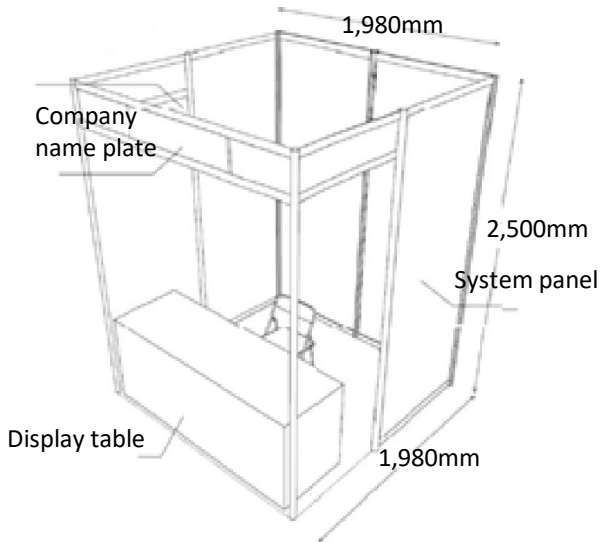

○ Eligible applicants:

Academic institutions such as universities, public institutions, etc.

○ Booth size: W1,980×D1,980×H2,500 (mm)

○ Furniture:

Display table covered with a white cloth (W1,800×D900×H approx.720(mm)), Company name plate, Lighting (FL40W), 1 chair (The no. of chairs depends on the no. of booths applied for.)

○ System panels are used for booths.

Pushpins and nails are not available on the panels to attach panel or poster.

○ 4 name badges per booth will be provided for the exhibition staff.

○ **1 meeting pass to participate in the meeting program will be provided.**

Application is required for the use of electricity (100V).

The electricity bill and costs for electrical installation work should be paid by the exhibitor.

Electricity bill

Up to 500W JPY33,000 (Incl.tax)

501W - 1KW JPY38,500 (Incl.tax)

2 outlets are provided per 1KW. Additional outlets and earth terminal require extra charges.

*For the use of over 1KW, JPY16,500 (Incl. tax) per 1KW will be added.

*200V power supply (single-/three-phase) needs another installation work and can be rather expensive.

If needed, please apply for electricity along with the booth.

◆Type D (Online exhibition): JPY165,000 /booth (Incl.tax)



○Applicable products & services:
Medical and life science research related instruments, reagents, disposables, computer systems including software, database, etc., and contract services.

○System:
Online conference system “Confit”.

○Information to be posted: Japanese & English, 1 page for each

- Company information, Product introduction, etc. (Text, image, video)
- Contact information, company URL, etc.

○Format

- Video: URL of YouTube etc.
- Image: jpg, png, gif etc.

○Application deadline:
April 28, 2023

○Image of Online Exhibition





The 46th Annual Meeting of the Japan Neuroscience Society

Donation



Donation

- Name: Donation for The 46th Annual Meeting of the Japan Neuroscience Society
- Application period: July 4, 2022 – August 4, 2023
- Use of donations: Donations will be used for the preparation and operation of The 46th Annual Meeting of the Japan Neuroscience Society and related events to be held in Sendai International Center, from August 1 to 4, 2023.
- Application: Please apply via an online application form on the sponsorship page of the meeting website. A receipt will be issued upon confirmation of payment.
- Bank account for payment:
- Bank: MUFG Bank
Branch: Jinbocho branch (013)
Account type: Ordinary
Account number: 1482925
Account name: NEUROSCIENCE2023 大会長 小林 和人
(ニューロサイエンスニセンニジュウサン コバヤシ カズト)
- Tax treatment: There is no tax exemption.
- Disclosure of information: We agree that the donors disclose their contributions such as the amount of donation and the recipient on the website etc. in accordance with their guidelines.
- Remarks: The company names that applied for donation will be published in the program booklet (only for applications received by April 28, 2023) and on the meeting website.
- Contact: Neuroscience 2023 Sponsorship Secretariat (c/o A & E Planning, Co., Ltd.)
E-mail : e-jns2023@aeplan.co.jp